

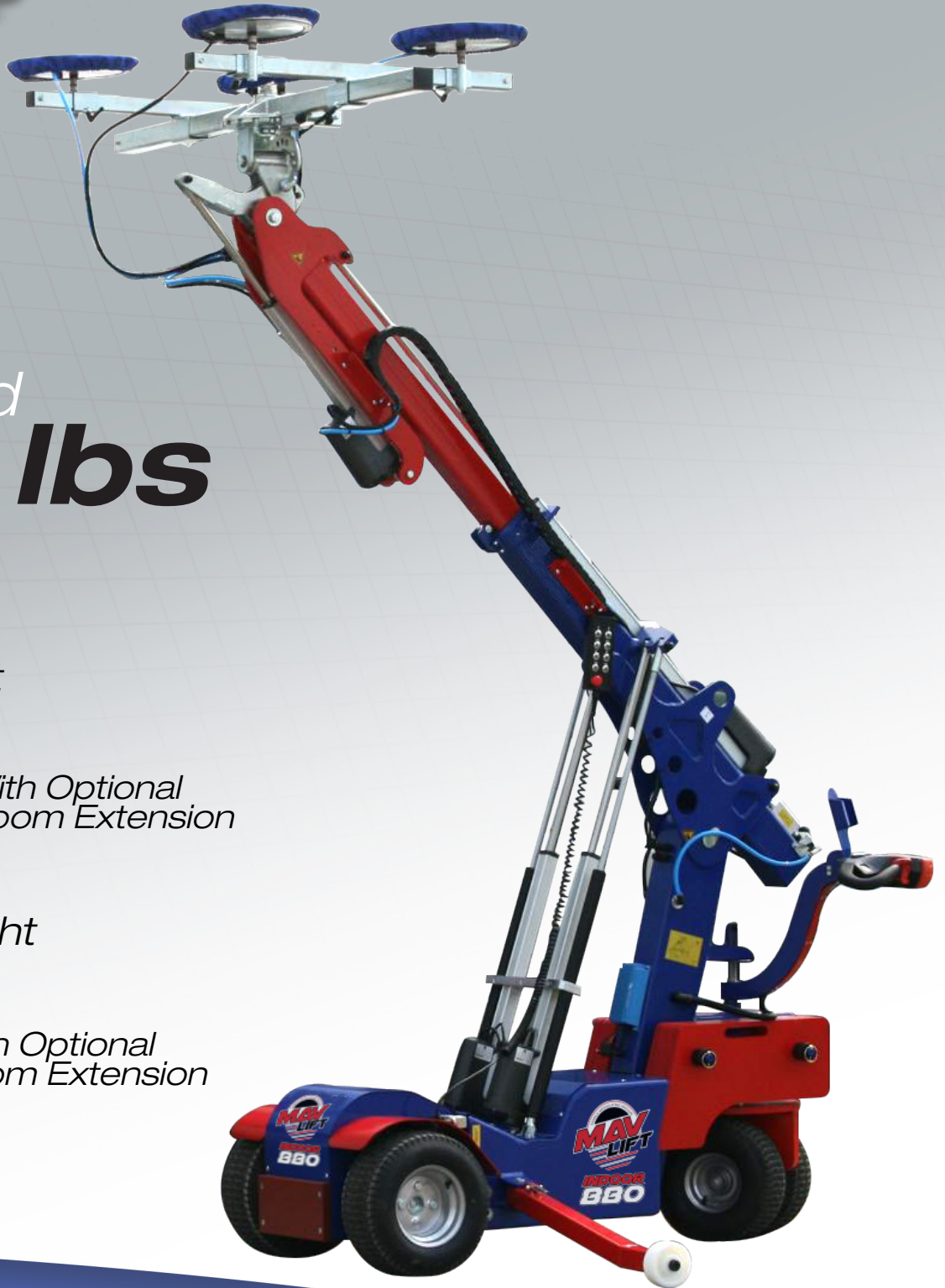

# OFFROAD BBO

## Glazing Robot



Max Load  
**880 lbs**

Vertical Working Height

**10' 5"**

**12' 3"** With Optional Boom Extension

Max Overhead Height

**12' 0"**

**14' 1"** With Optional Boom Extension



[MAVLift.com](http://MAVLift.com)



When your project requires a slightly larger unit, the MAVLift 880 is ready for service. Offering the MAVLift's signature Synchronous Controls that keep the suction unit at a constant inclination angle automatically, the MAVLift 880 performs with precision while lifting up to 880 lbs on a compact chassis measuring less than 3 feet across.

Add the optional boom extension and you now have a precision robot that can install glass at heights of almost 14 feet overhead.

With a variety of optional features and accessories, customize your MAVLift 880 into a smart lifting robot that works for you!

# Dimensions

## MAV OFFROAD LIFT 880 Dimensions

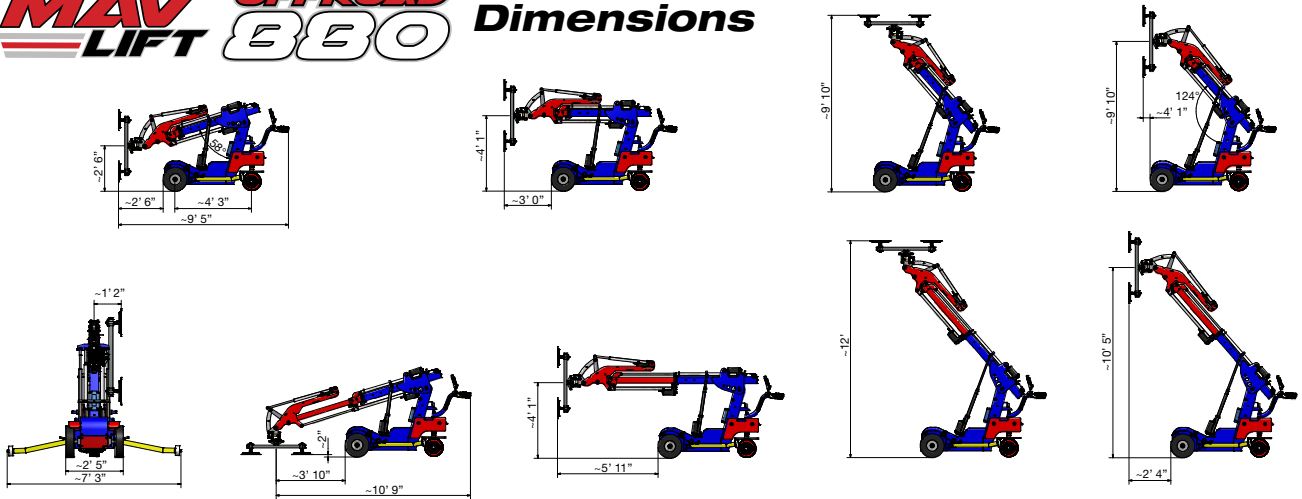

## Dimensions with Optional Boom Extension

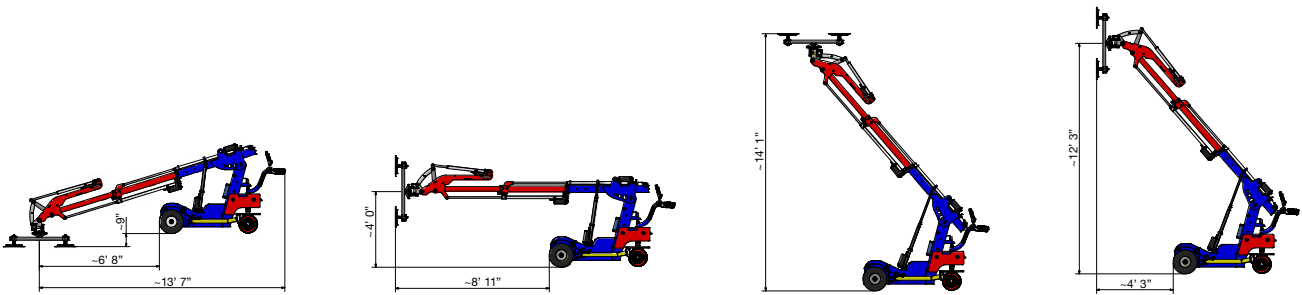





# OFFROAD 880

## Specifications

### Technical Data

Max Load Capacity	880 lbs
Machine Weight (Without Counterweights)	1209 lbs
Machine Weight (With removable Counterweights installed)	1821 lbs
Jib Angle	125°
Maximum Permitted Slope	17°
Powered Lateral Sideshift	4"
Power Requirements	Battery: 110v/240v Charger Pump: 12v DC
Vacuum System	2 Vacuum Pumps 4 Cups

### Standard Features

- Lifting Unit electrically turns in all directions and telescopes to the front
- Synchronous Controls- automatically keeps a constant inclination angle of vacuum unit
- Adjustable Suction Frame
- Wireless Remote Control
- Suitable for Overhead Lifting
- 4" Lateral Sideshift (left and right)
- 180° Suction Unit Rotation (manual left and right)
- 90° Slew of Vacuum Unit (left and right)
- Dual Vacuum Circuit with two pumps and two Vacuum Reserve Tanks
- Robotic Arm powered by electric actuators for precision control
- Operates on two 12v DC Rechargeable Batteries or while plugged into standard outlet

### Safety Features

- Overload Switch
- Stop Switch
- Vacuum Lost/Overloading Indicator
- Low Battery Indicator Light

### Accessories

- Load Forks - Utilize your MAVLift for material handling
- Hook Adapter - Remove the cup system and add a lifting hook to your MAVLift
- Forklift Platform - Utilize your MAVLift as an extension of your forklift
- LED Light - LED with magnetic socket powered by the MAVLift's battery pack
- Loading Ramp - 8' x 3' load ramps for easy loading into a transport vehicle or trailer (2200 lbs max capacity)
- Weather Cover for MAVLift Offroad 880

### Optional Features

- Advanced Articulated Joint- Allows for additional electric articulation of suction unit -swivel from the horizontal plane to overhead
- Electrical Rotation +/- 45° – In addition the unit can manually rotated 360° and fixable in four position- must be combined with Advanced Articulated Joint
- Electrical Slewing +/- 90° – Electrically powered slewing of suction frame- not combinable with electrical rotation- must be combined with Advanced Articulated Joint
- Electrical Additional Boom Extension- Adds 3' of electrically actuated Boom- must be combined with Advanced Articulated Joint
- Manual Boom Extension- Adds 3' of additional boom that is manually actuated with 5 pin positions



[MAVLift.com](http://MAVLift.com)